

### Kabebari batten detail

#### Profile: Mikadzuki 44x18mm

Base: 0.166kg/m

Cover: 0.202kg/m

Total: 0.368kg/m

\*End cover: 0.213kg/m

Batten thickness: 1.0mm

End cap thickness: 2.5mm

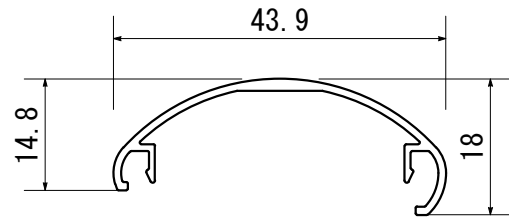

\*End cover

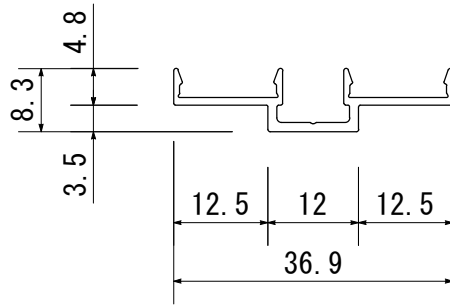
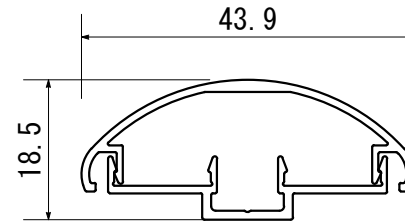
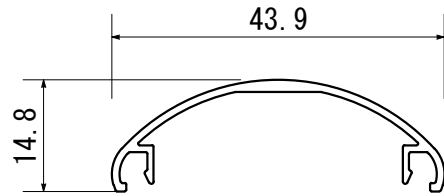
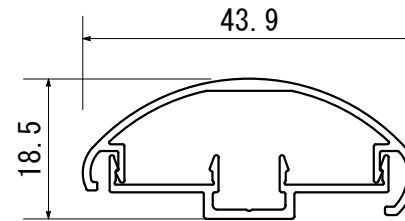



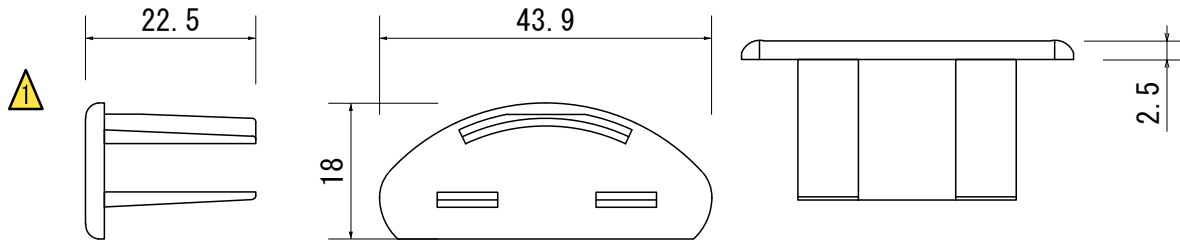

### Endcap detail

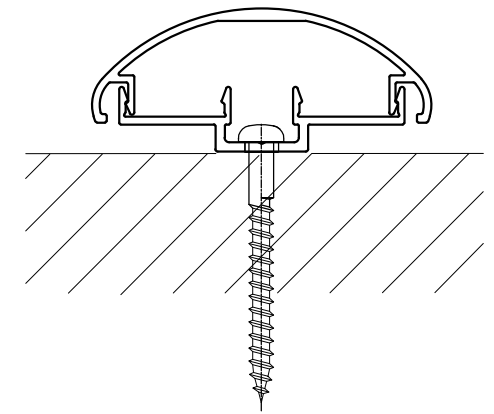





### Installation detail



			Product Name				Project Name	Creation Date	Page	Scale	Projection
	<b>Install</b>	Never strike extrusion directly with a hammer or rubber mallet. Use a pine plank between the tool and the extrusion to avoid surface damage or denting.	Ever Art Wood - Kabebari				Mikadzuki 44x18		1 of 2	1:1	
	<b>End caps</b>	Secure to batten with screw or exterior grade adhesive (Sikaflex), OR Screw fix or apply exterior grade adhesive (Sikaflex) to secure cap to batten.	Approval	Chek	Drawing	Design	Customer	Distributor		Manufacturer	
No.	DATE							<b>covet</b>			

## Kabebari Batten Installation Guide

- Aluminium can be damaged if mishandled. Never strike directly with a hammer or rubber mallet. Use a pine plank between the striking rubber mallet and the extrusion to avoid surface damage or denting.
- Cut aluminium with a drop saw using an aluminium blade.
- Always cap ends of extrusions with supplied end caps or a flashing to avoid moisture ingress.
- Plastic end caps must be securely inserted with screws supplied or sikafelx applied to the inside of the extrusion before inserting. This will prevent slippage of the extrusion.
- Metal end caps (painted) must be screwed to the extrusion.
- All end caps can only be applied to straight 90 degree cuts. They cannot be applied to angle end cuts.
- Ensure appropriate screws are used to suit the substrate you are fastening to. It is important to use stainless steel or bi-metal screws for all metal surfaces impacted when fastening (i.e. furring channels, top hats, steel frames). This will prevent galvanic reaction between the screw/substrate and aluminium extrusion.
- Fasten at maximum 1 metre spans. Please contact Covet for further information.
- Always fasten the male (base) section first. The female (top section) clips over the top. They can also slide on if necessary.

			Product Name				Project Name	Creation Date	Page	Scale	Projection
	<b>Install</b>	Never strike extrusion directly with a hammer or rubber mallet. Use a pine plank between the tool and the extrusion to avoid surface damage or denting.	Ever Art Wood - Kabebari				Mikadsuki 44x18		2 of 2	1:1	
	<b>End caps</b>	Secure to batten with screw or exterior grade adhesive (Sikaflex), OR Screw fix or apply exterior grade adhesive (Sikaflex) to secure cap to batten.	Approval	Chek	Drawing	Design	Customer	Distributor		Manufacturer	
No.	DATE							<b>covet</b>		